

# Tennessee Comprehensive Assessment Program

# TCAP

## Math | Grade 7 Practice Test Subpart 1, Subpart 2, & Subpart 3

---

Student Name

---

Teacher Name



Published under contract with the Tennessee Department of Education by Questar Assessment Inc., 5550 Upper 147th Street West, Minneapolis, MN 55124.  
Copyright © 2016 by Tennessee Department of Education. All rights reserved. No part of this publication may be copied, reproduced, or distributed in any form or by any means, or stored in a database or retrieval system, without the prior express written consent of the Tennessee Department of Education and Questar Assessment Inc.

**Test Administrator Instructions:**

This practice test has Subpart 1, Subpart 2, and Subpart 3. There is also an answer document and an answer key at the end of this document. It is recommended that you print one copy of this practice test and pull the answer key before copying and distributing the practice test and answer document to your students.

This practice test is representative of the operational test but is shorter than the actual operational test. To see the details about the operational test, please see the blueprints located on the Tennessee Department of Education website.

**Directions**

Subpart 1 of this Practice Test booklet contains sample items for Grade 7 Math. You may use this test booklet for scratch paper or to make notes, but you must mark your answers on your answer document.

**You MAY NOT use a calculator in Subpart 1 of this test booklet.**

**Sample 1: Selected-Response**

1. Which expressions are equivalent to  $4(9 + 3)$ ?
- A.  $4(12)$
  - B.  $36 + 3$
  - C.  $36 + 12$
  - D.  $4 + (9 + 3)$
  - E.  $(9 + 3) + (9 + 3) + (9 + 3) + (9 + 3)$

**Sample 2: Table**

2. Select **True** or **False** in the table on your answer document to indicate whether each comparison is true.

	<b>True</b>	<b>False</b>
$3^2 < \frac{4}{9} + \frac{2}{3}$	<input type="radio"/>	<input type="radio"/>
$2(2^3 + 14 \cdot 2) \geq 9 \cdot 8$	<input type="radio"/>	<input type="radio"/>
$16.2 \cdot 3 - 24.6 < 72 \div 3 + 2.78$	<input type="radio"/>	<input type="radio"/>



1. Evaluate:

$$4\frac{2}{3} - \left(-1\frac{4}{5}\right)$$

- A.  $-7\frac{2}{15}$
- B.  $2\frac{13}{15}$
- C.  $6\frac{7}{15}$
- D.  $7\frac{2}{15}$

2. Solve for  $m$ :

$$-\frac{2}{9}m + 12 = -8$$

Write your answer in the space provided on your answer document.

3. While on a camping trip, Calvin was monitoring the temperature.

- In the afternoon, the temperature was  $-4^{\circ}\text{C}$ .
- As the evening progressed, the temperature dropped  $7^{\circ}\text{C}$ .
- By mid-morning the next day, the temperature had risen  $3^{\circ}\text{C}$ .

What was the temperature, in degrees Celsius, after these changes?

Write your answer in the space provided on your answer document.



4. A square garden has sides that are 10 feet in length.

Using the graph on your answer document, draw a scale drawing of the garden using a scale of 3 centimeters = 5 feet.

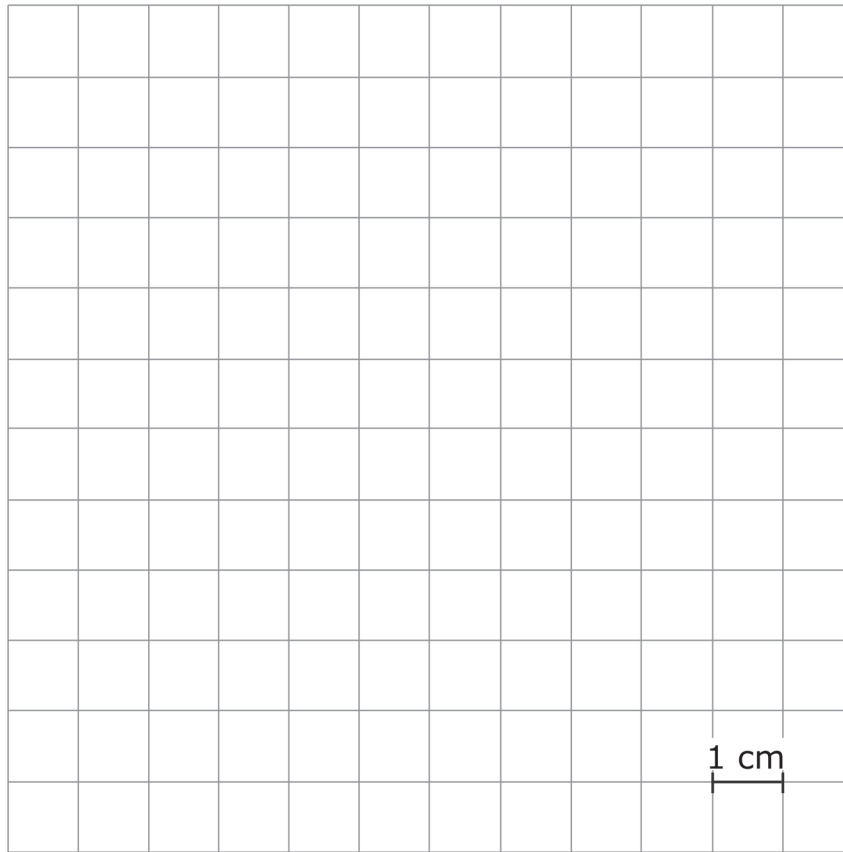



5. At a local gym, a random sample of 75 members took a survey about their favorite type of exercise.

### Gym Survey Results

Type	Number of Members
Bicycling	18
Exercise Classes	22
Running on Treadmill	15
Weight Lifting	20

There are 350 total gym members. Based on the results of the survey, what is the **most** reasonable estimate for the number of gym members who prefer running on the treadmill?

- A. 23  
B. 70  
C. 85  
D. 93
6. Look at the rational numbers in both lists.

Match each fraction on the left with its equivalent decimal on the top. Mark your answers on your answer document.

	Decimals			
Fractions	0.375	$0.37\overline{5}$	$0.\overline{45}$	0.45
$\frac{5}{11}$	<input type="radio"/>	<input type="radio"/>	<input type="radio"/>	<input type="radio"/>
$\frac{3}{8}$	<input type="radio"/>	<input type="radio"/>	<input type="radio"/>	<input type="radio"/>



7. The members of two running clubs entered their daily running totals into a computer program. The leaders of the two clubs randomly selected 25 days of the year and created box-and-whisker plots showing the total number of miles run by club members on the 25 selected days.

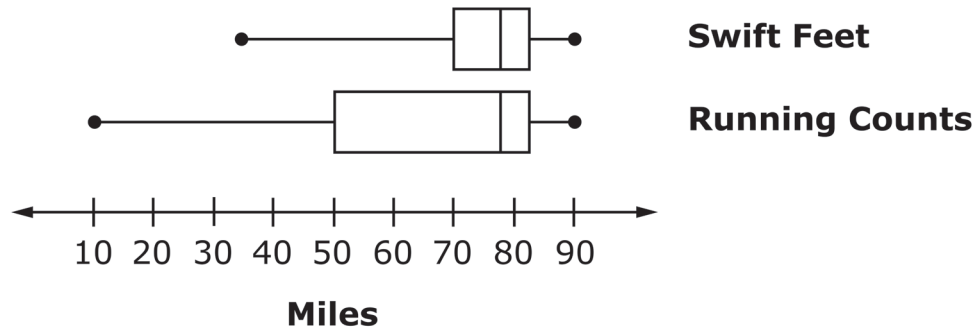

Which inference about the running groups is valid based on the samples given?

- A. The Swift Feet club has fewer members than the Running Counts club.
- B. The members of the Running Counts club run more slowly than the members of the Swift Feet club.
- C. The median number of miles run by members of both clubs was close to 80 miles.
- D. The total miles run by members of both clubs vary by about the same amount.





8. A right square pyramid is sliced by a horizontal plane parallel to the base.

Using the graph on your answer document, draw a possible plane section of the right square pyramid as described.

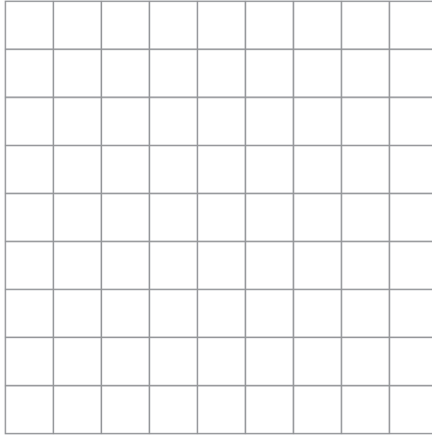

9. Nancy is buying a new pair of boots. The store is having a sale and all boots are 20% off.

**Part A**

Choose an expression that can represent the sale price of the boots where  $x$  is the original price of the boots.

- A.  $0.2x$
- B.  $0.8x$
- C.  $1.2x$

**Part B**

This means that the sale price of the boots is \_\_\_\_\_ of the original cost.

- A. 20%
- B. 80%
- C. 120%



10. Which situation is **best** described by this number line?

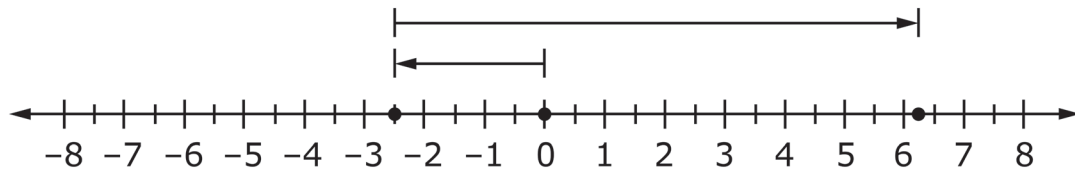

- A. Ryder owed his mom \$2.50. He does some chores and makes \$6.25.
- B. Ryder had \$6.25. He needs to buy school supplies and ends up owing his mother \$2.50.
- C. Ryder owed his mom \$2.50. He babysits his sister and makes \$8.75.
- D. Ryder owed his mom \$2.50. He also owes his father \$8.75.
11. Select **all** expressions shown that are equivalent to  $\frac{3}{5}a + 10$ .

A.  $\frac{1}{5}a + 10 + \frac{2}{5}a$

B.  $a\left(\frac{3}{5} + 10\right)$

C.  $14 + \frac{3}{5}a - 4$

D.  $\frac{1}{5}(3a + 50)$

E.  $10 + \frac{2}{5}a - a + \frac{1}{5}a$



- 12.** Karen gets 3 books from her book club for \$12. She creates a graph to show the relationship between the number of books and the total cost of the books. Points on the graph include  $(0,0)$ ,  $(1, 4)$ ,  $(2, 8)$ , and  $(3, 12)$ .

**Part A**

Choose the ordered pair that represents unit rate.

- A.**  $(0, 0)$
- B.**  $(1, 4)$
- C.**  $(2, 8)$
- D.**  $(3, 12)$

**Part B**

The  $x$ -value of the ordered pair represents the \_\_\_\_\_.

- A.** number of books
- B.** cost of the books

**Part C**

The  $y$ -value of the ordered pair represents the \_\_\_\_\_.

- A.** number of books
- B.** cost of the books



13. What is the value of  $x$ ?

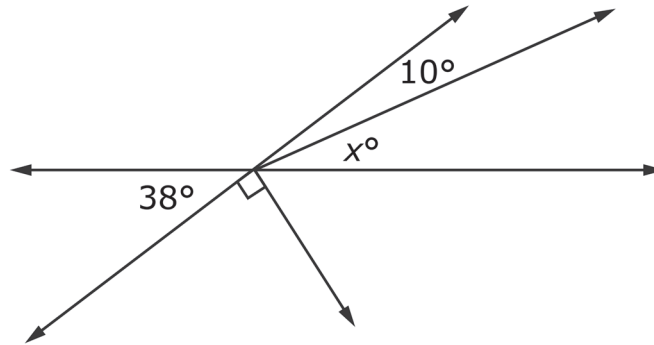

Write your answer in the space provided on your answer document.



**This is the end of Subpart 1 of the Grade 7 Math Practice Test.  
Proceed to Subpart 2.**

**Directions**

Subpart 2 of this Practice Test booklet contains sample items for Grade 7 Math. Write your answers in your answer document.

**You MAY use a calculator in Subpart 2 of this test booklet.**

**14.** Select **all** of the expressions that are equivalent to  $\frac{2}{3}(9x + 6) - \frac{1}{2}(8x - 4)$ .

**A.**  $2(x + 1)$

**B.**  $2x + 6$

**C.**  $2x + 2$

**D.**  $2(x + 3)$

**E.**  $8x$

**15.** A random sample of 40 blocks was removed from a container. The blocks removed included 9 black, 15 red, 11 yellow, and 5 orange blocks.

Based on the experimental results, determine the probability of removing each color of block from the container.

Mark the table on your answer document to match each color on the left with the probability for that color on the top.

	$\frac{1}{8}$	$\frac{3}{8}$	0.225	0.275
Black	<input type="radio"/>	<input type="radio"/>	<input type="radio"/>	<input type="radio"/>
Red	<input type="radio"/>	<input type="radio"/>	<input type="radio"/>	<input type="radio"/>
Yellow	<input type="radio"/>	<input type="radio"/>	<input type="radio"/>	<input type="radio"/>
Orange	<input type="radio"/>	<input type="radio"/>	<input type="radio"/>	<input type="radio"/>



16. The measurements of a figure are shown.

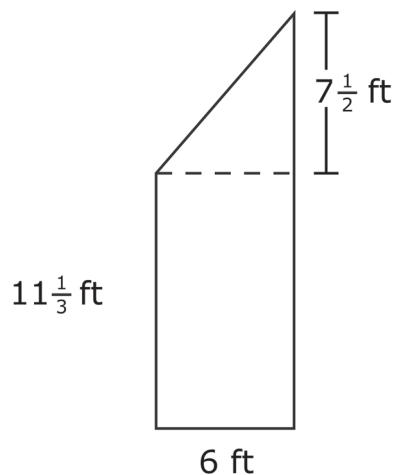

What is the area, in square feet, of the figure?

Write your answer in the space provided on your answer document.

17. Sandals are on sale for 30% off. The original price of one pair of sandals is \$15.

What is the total cost, in dollars, of **two** pairs of sandals at the sale price and including 7% sales tax?

Write your answer in the space provided on your answer document.



18. Select **all** that represent a proportional relationship.

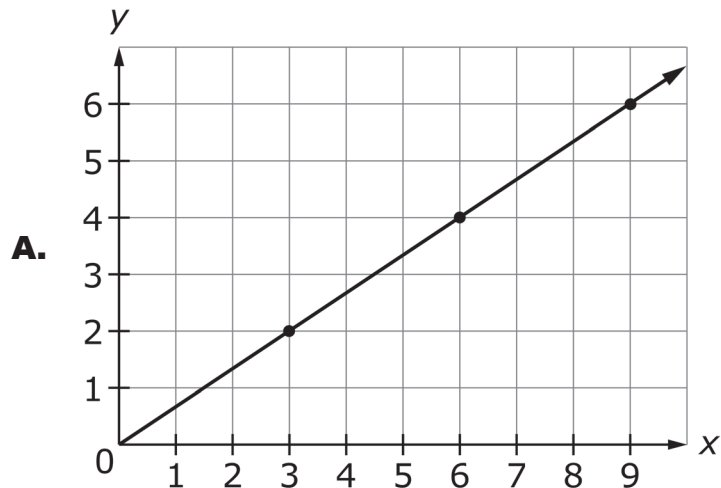

**B.**

$x$	$y$
2	3
4	4
6	5
8	6

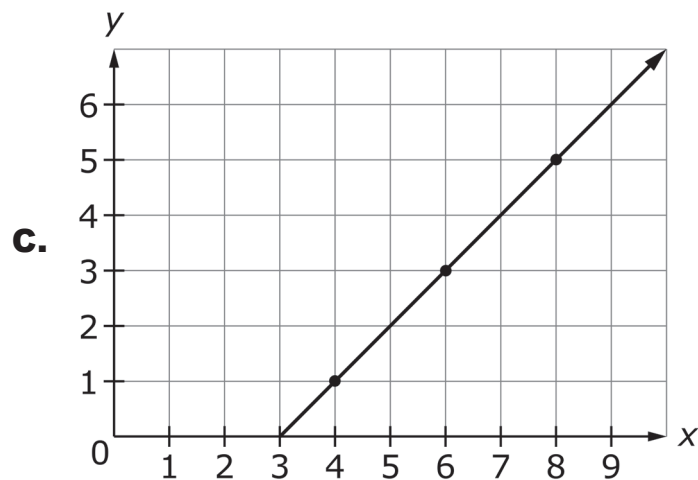

**D.**

$x$	$y$
3	1
6	2
9	3
12	4



- 19.** In the year 2010, the population of Kingsford was 8000. By 2014 the population had increased by 15% and  $\frac{2}{5}$  of the population was age 12 or under.

How many people in Kingsford were age 12 or under in the year 2014?

- A.** 1200  
**B.** 3200  
**C.** 3680  
**D.** 5520
- 20.** Margaret is placing a picture on a wall that is  $7\frac{1}{2}$  feet long. The picture is 27 inches across and will be hung in the center of the wall, as shown in the drawing.

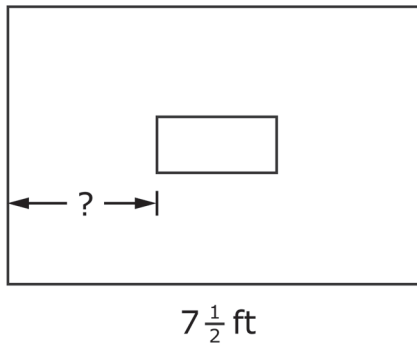

What is the distance, in inches, from one edge of the wall to the picture?

Write your answer in the space provided on your answer document.





- 21.** Nathan conducted a probability experiment in which he dropped 5 toothpicks at the same time. He recorded the number of toothpicks that were touching when they landed. He then picked up the toothpicks and repeated the experiment. After dropping the toothpicks and recording the results 50 times, Nathan concluded that it was more likely than not that at least 2 toothpicks would be touching when they landed. He also observed that sometimes no toothpicks were touching. Which **best** represents the probability that at least 2 toothpicks will be touching when they land?

**A.**  $\frac{1}{4}$

**B.**  $\frac{1}{2}$

**C.**  $\frac{3}{4}$

**D.** 1

- 22.** The lengths or angles given represent the sides or angles of a triangle.

For each set of angles or sides on the left, mark the appropriate box on your answer document: Unique Triangle, More Than One Triangle, or No Triangle.

	<b>Unique Triangle</b>	<b>More Than One Triangle</b>	<b>No Triangle</b>
5 cm, 10 cm, 12 cm	<input type="radio"/>	<input type="radio"/>	<input type="radio"/>
40°, 50°, 80°	<input type="radio"/>	<input type="radio"/>	<input type="radio"/>
8 ft, 12 ft, 20 ft	<input type="radio"/>	<input type="radio"/>	<input type="radio"/>
28°, 51°, 101°	<input type="radio"/>	<input type="radio"/>	<input type="radio"/>



- 23.** Ms. Allen filled a glass jar with marbles. Students guessed the number of marbles in the jar.

Jen guessed there were 127 marbles in the jar. The jar contained 132 marbles.

To the nearest tenth of a percent, what is the percentage of error for Jen's guess?

Write your answer in the space provided on your answer document.



**This is the end of Subpart 2 of the Grade 7 Math Practice Test.  
Proceed to Subpart 3.**



**Directions**

Subpart 3 of this Practice Test booklet contains sample items for Grade 7 Math. Write your answers on your answer document.

**You MAY use a calculator in Subpart 3 of this test booklet.**



24. Use the information shown in the graph to complete the sentences.

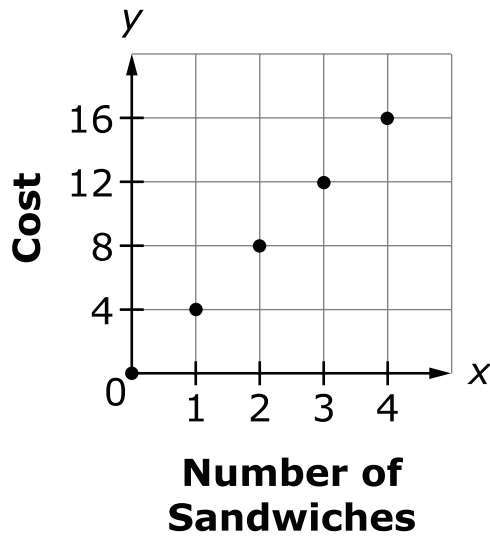

**Part A**

Select the ordered pair that would correctly complete the sentence.

The point (\_\_\_, \_\_\_) represents the unit rate.

- A. (0, 0)
- B. (1, 4)
- C. (2, 8)
- D. (3, 12)
- E. (4, 16)

**Part B**

Choose one number from Box A for blank A on your answer document and one number from Box B on your answer document for blank B to correctly complete the sentence.

The point (3, 12) means that for \_\_\_\_\_.

- A. \$3 you can buy 3 sandwiches
- B. \$3 you can buy 12 sandwiches
- C. \$12 you can buy 3 sandwiches
- D. \$12 you can buy 12 sandwiches



25. Which expression is equivalent to  $\frac{12}{5}x - 2$ ?

A.  $\frac{12x - 2}{5}$

B.  $2\left(\frac{2}{5}x - 1\right)$

C.  $\frac{2}{5}(6x - 1)$

D.  $\frac{1}{5}(12x - 10)$

26. The first column contains five pairs of relationships. Determine if each pair forms a proportional relationship. Mark "Proportional" or "Not Proportional" for each relationship in the table on your answer document.

	Proportional	Not Proportional
3 games played in 2.5 hours and 9 games played in 7.5 hours	<input type="radio"/>	<input type="radio"/>
18 points scored in 3 games and 20 points scored in 5 games	<input type="radio"/>	<input type="radio"/>
2 apples for \$1.50 and 8 apples for \$6.50	<input type="radio"/>	<input type="radio"/>
\$35.00 for 12.5 gallons of gasoline and \$16.80 for 6 gallons of gasoline	<input type="radio"/>	<input type="radio"/>
15 miles from home after 20 minutes and 36 miles from home after 48 minutes	<input type="radio"/>	<input type="radio"/>



- 27.** Chris has \$1500 in the bank and takes out  $\frac{1}{3}$  of the money.

He decides to use  $\frac{3}{5}$  of the money he took from his account to pay part of a \$700 debt. After he makes this payment, how much, in dollars, does he still owe?

Write your answer in the space provided on your answer document.

- 28.** Trinity operates a lemonade stand every weekend. This weekend, she made 45% more money than the previous weekend. The previous weekend she made  $x$  dollars.

Write an expression that shows how much money Trinity made this weekend in the space provided on your answer document.

- 29.** A recipe for 1 pumpkin pie calls for  $1\frac{1}{4}$  cups of sugar. Alaina has only  $\frac{1}{2}$  cup of sugar and she needs to make 4 pumpkin pies.

How much more sugar will Alaina need to make all 4 pies?

Write your answer in the space provided on your answer document.



- 30.** Jerry is mowing his lawn. It takes him  $\frac{1}{6}$  of an hour to mow  $\frac{3}{20}$  of his yard.  
How much time will it take him to mow the entire yard?

**A.**  $\frac{19}{60}$  hr

**B.**  $\frac{9}{10}$  hr

**C.**  $\frac{10}{9}$  hr

**D.**  $\frac{10}{3}$  hr



31. Each of the three tables shows a relationship.

**Cost of Movies**

Number of Movies	Cost (\$)
1	\$10
2	\$15
3	\$20
4	\$25

**Photo Album**

Number of Pages	Number of Pictures
1	15
2	30
3	55
4	75

**Minutes Read**

Number of Days	Minutes Read
1	20
2	40
3	60
4	80

**Part A**

The table that shows a proportional relationship is the \_\_\_\_\_ table.

- A. Cost of Movies
- B. Photo Album
- C. Minutes Read

**Part B**

The constant of proportionality is \_\_\_\_\_.

- A. 5
- B. 10
- C. 15
- D. 20





- 32.** Last month, Karmin made \$480 working for 30 hours. This month, she will get a 15% increase in the amount she earns per hour. What will be her hourly rate, in dollars per hour, after the raise?

Write your answer in the space provided on your answer document.

- 33.** Audra makes and sells bracelets. It costs her \$8 to make a bracelet, and she sells them at a markup of 210%. Audra wants to have a sale, so she marks all of her bracelets 20% off the normal selling price. What will be the price of each bracelet during the sale?

- A.** \$15.20
- B.** \$16.80
- C.** \$19.84
- D.** \$23.20

- 34.** Over the summer, Marty read 4 times as many pages as the number of pages Nelson and Jennifer read combined. Marty read 1860 pages and Nelson read 240 pages.

**Part A**

Select an equation that could be solved to find the number of pages,  $p$ , Jennifer read.

- A.**  $1860 + 240 = 4p$
- B.**  $4(240 + p) = 1860$
- C.**  $1860 - (960 \div 4) = p$
- D.**  $240 + 4p = 1860$

**Part B**

How many pages did Jennifer read?

Write your answer in the space provided on your answer document.



35. Margo records the relationship between the amounts of raisins and peanuts she mixes to create different batches of her trail mix.

Batch	A	B	C	D	E
Ounces of raisins	1	2	3	4	5
Cups of peanuts	1.25	2.5	3.75	5	6.25

**Part A**

Choose the ordered pair that has a  $y$ -coordinate that is the constant of proportionality for the relationship.

- A. (1, 1.25)
- B. (2, 2.5)
- C. (4, 5)

**Part B**

Based on the proportional relationship, 8 ounces of raisins require \_\_\_\_\_ cups of peanuts.

- A. 6.5
- B. 7.75
- C. 10
- D. 11.25



36. The music preferences of a random sample of 75 middle-school students are recorded in the table. There are 1257 students in the middle school.

Music Preference Sample	
Music Type	Number of Students
Rock	19
Pop	27
Country	29

Select **two** statements that are valid for the entire middle school based on the information from the random sample.

- A. Approximately 452 of the students prefer pop music.
- B. Approximately 19 of the students prefer rock music.
- C. Approximately 39% of the students prefer country music.
- D. Approximately  $\frac{1}{3}$  of the students prefer rock music.

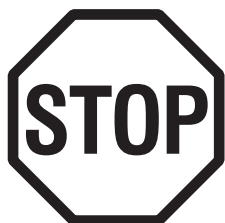

**This is the end of the test.**

---

**This page is intentionally left blank.**

## TNReady Math Reference Sheet—Grade 7

1 inch = 2.54 centimeters

1 meter = 39.37 inches

1 mile = 5,280 feet

1 mile = 1,760 yards

1 mile = 1.609 kilometers

1 kilometer = 0.62 mile

1 pound = 16 ounces

1 pound = 0.454 kilograms

1 kilogram = 2.2 pounds

1 ton = 2000 pounds

1 cup = 8 fluid ounces

1 pint = 2 cups

1 quart = 2 pints

1 gallon = 4 quarts

1 gallon = 3.785 liters

1 liter = 0.264 gallons

1 liter = 1000 cubic centimeters

---

**This page is intentionally left blank.**

Name: \_\_\_\_\_

**Subpart 1 Sample Questions**

1.    (A)   (B)   (C)   (D)   (E)

2.

	True	False
$3^2 < \frac{4}{9} + \frac{2}{3}$	<input type="radio"/>	<input type="radio"/>
$2(2^3 + 14 \cdot 2) \geq 9 \cdot 8$	<input type="radio"/>	<input type="radio"/>
$16.2 \cdot 3 - 24.6 < 72 \div 3 + 2.78$	<input type="radio"/>	<input type="radio"/>

**Subpart 1 Practice Test Questions**

1.    (A)   (B)   (C)   (D)

2.

3.

4.



5.

- (A) (B) (C) (D)

6.

	Decimals			
Fractions	0.375	$0.37\overline{5}$	$0.\overline{45}$	0.45
$\frac{5}{11}$	<input type="radio"/>	<input type="radio"/>	<input type="radio"/>	<input type="radio"/>
$\frac{3}{8}$	<input type="radio"/>	<input type="radio"/>	<input type="radio"/>	<input type="radio"/>

7.

- (A) (B) (C) (D)



8.

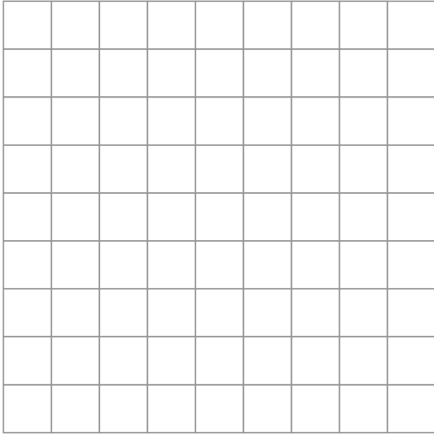

9. Part A: (A) (B) (C)

Part B: (A) (B) (C)

10. (A) (B) (C) (D)

11. (A) (B) (C) (D) (E)

12. Part A: (A) (B) (C) (D)

Part B: (A) (B)

Part C: (A) (B)

13.

Subpart 2 Practice Test Questions

14. (A) (B) (C) (D) (E)

15.

	$\frac{1}{8}$	$\frac{3}{8}$	0.225	0.275
Black	<input type="radio"/>	<input type="radio"/>	<input type="radio"/>	<input type="radio"/>
Red	<input type="radio"/>	<input type="radio"/>	<input type="radio"/>	<input type="radio"/>
Yellow	<input type="radio"/>	<input type="radio"/>	<input type="radio"/>	<input type="radio"/>
Orange	<input type="radio"/>	<input type="radio"/>	<input type="radio"/>	<input type="radio"/>

16.

17.

18. (A) (B) (C) (D)

19. (A) (B) (C) (D)

20.

21. (A) (B) (C) (D)

22.

	Unique Triangle	More Than One Triangle	No Triangle
5 cm, 10 cm, 12 cm	<input type="radio"/>	<input type="radio"/>	<input type="radio"/>
40°, 50°, 80°	<input type="radio"/>	<input type="radio"/>	<input type="radio"/>
8 ft, 12 ft, 20 ft	<input type="radio"/>	<input type="radio"/>	<input type="radio"/>
28°, 51°, 101°	<input type="radio"/>	<input type="radio"/>	<input type="radio"/>

23.

**Subpart 3 Practice Test Questions**

24. **Part A:** (A) (B) (C) (D) (E)

**Part B:** (A) (B) (C) (D)

25. (A) (B) (C) (D)

26.

	<b>Proportional</b>	<b>Not Proportional</b>
3 games played in 2.5 hours and 9 games played in 7.5 hours	<input type="radio"/>	<input type="radio"/>
18 points scored in 3 games and 20 points scored in 5 games	<input type="radio"/>	<input type="radio"/>
2 apples for \$1.50 and 8 apples for \$6.50	<input type="radio"/>	<input type="radio"/>
\$35.00 for 12.5 gallons of gasoline and \$16.80 for 6 gallons of gasoline	<input type="radio"/>	<input type="radio"/>
15 miles from home after 20 minutes and 36 miles from home after 48 minutes	<input type="radio"/>	<input type="radio"/>

27.

28.

29.

30. (A) (B) (C) (D)

31. Part A: (A) (B) (C)

Part B: (A) (B) (C) (D)

32.

33. (A) (B) (C) (D)

34. Part A: (A) (B) (C) (D)

Part B:

35. Part A: (A) (B) (C)

Part B: (A) (B) (C) (D)

36. (A) (B) (C) (D)

**Subpart 1 Sample Questions**

1. ● (B) ● (D) ●

2.

	True	False
$3^2 < \frac{4}{9} + \frac{2}{3}$	<input type="radio"/>	<input checked="" type="radio"/>
$2(2^3 + 14 \cdot 2) \geq 9 \cdot 8$	<input checked="" type="radio"/>	<input type="radio"/>
$16.2 \cdot 3 - 24.6 < 72 \div 3 + 2.78$	<input checked="" type="radio"/>	<input type="radio"/>

**Subpart 1 Practice Test Questions**

1. (A) (B) ● (D)

2. 90

3. -8

4.

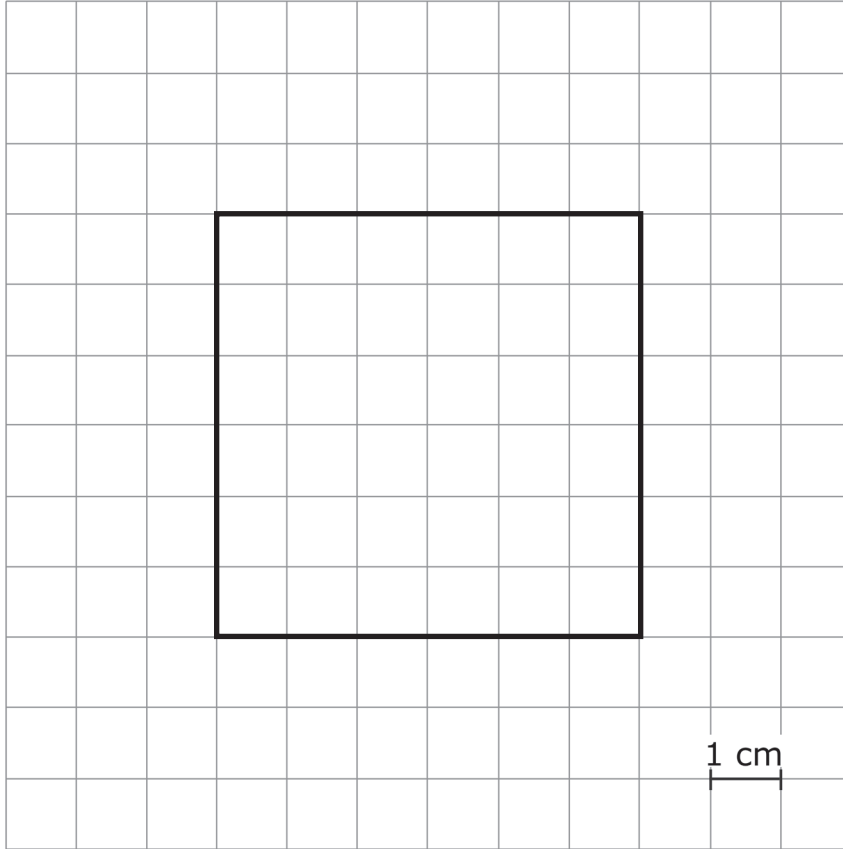

Square may be in any position but must be a 6 by 6 square.

5.

- Ⓐ ● Ⓒ Ⓓ

6.

	Decimals			
Fractions	0.375	$0.37\overline{5}$	$0.\overline{45}$	0.45
$\frac{5}{11}$	<input type="radio"/>	<input type="radio"/>	<input checked="" type="radio"/>	<input type="radio"/>
$\frac{3}{8}$	<input checked="" type="radio"/>	<input type="radio"/>	<input type="radio"/>	<input type="radio"/>

7.

- Ⓐ Ⓑ ● Ⓓ

8.

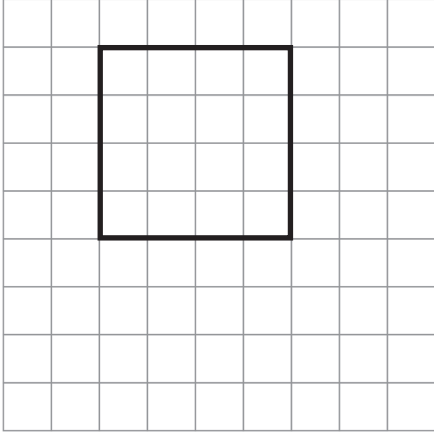

Any square is correct.

9. **Part A:**  A  B  C

**Part B:**  A  B  C

10.  A  B  C  D

11.  A  B  C  D  E

12. **Part A:**  A  B  C  D

**Part B:**  A  B

**Part C:**  A  B

13. 28

Subpart 2 Practice Test Questions

14.  A  B  C  D  E

15.

	$\frac{1}{8}$	$\frac{3}{8}$	0.225	0.275
Black	<input type="radio"/>	<input type="radio"/>	<input checked="" type="radio"/>	<input type="radio"/>
Red	<input type="radio"/>	<input checked="" type="radio"/>	<input type="radio"/>	<input type="radio"/>
Yellow	<input type="radio"/>	<input type="radio"/>	<input type="radio"/>	<input checked="" type="radio"/>
Orange	<input checked="" type="radio"/>	<input type="radio"/>	<input type="radio"/>	<input type="radio"/>



16. 90.5

17. 22.47

18. ● (B) (C) ●

19. (A) (B) ● (D)

20. 31.15 or an equivalent value

21. (A) (B) ● (D)

22.

	Unique Triangle	More Than One Triangle	No Triangle
5 cm, 10 cm, 12 cm	●	○	○
40°, 50°, 80°	○	○	●
8 ft, 12 ft, 20 ft	○	○	●
28°, 51°, 101°	○	●	○

23. 3.8

**Subpart 3 Practice Test Questions**

**24. Part A:**  A  B  C  D  E

**Part B:**  A  B  C  D

**25.**  A  B  C  D

**26.**

	<b>Proportional</b>	<b>Not Proportional</b>
3 games played in 2.5 hours and 9 games played in 7.5 hours	<input checked="" type="radio"/>	<input type="radio"/>
18 points scored in 3 games and 20 points scored in 5 games	<input type="radio"/>	<input checked="" type="radio"/>
2 apples for \$1.50 and 8 apples for \$6.50	<input type="radio"/>	<input checked="" type="radio"/>
\$35.00 for 12.5 gallons of gasoline and \$16.80 for 6 gallons of gasoline	<input checked="" type="radio"/>	<input type="radio"/>
15 miles from home after 20 minutes and 36 miles from home after 48 minutes	<input checked="" type="radio"/>	<input type="radio"/>

**27.** 400

**28.**  $1.45x$

**29.** 4.5

**30.**  A  B  C  D

**31. Part A:**  A  B  C

**Part B:**  A  B  C  D

**32.** 18.4

**33.**  A  B  C  D

**34. Part A:**  A  B  C  D

**Part B:** 225

**35. Part A:**  A  B  C

**Part B:**  A  B  C  D

**36.**  A  B  C  D