

Tennessee Comprehensive Assessment Program

TCAP

Science | Grade 6
Practice Test

Student Name

Teacher Name



Published under contract with the Tennessee Department of Education by Questar Assessment Inc., 5550 Upper 147th Street West, Minneapolis, MN 55124. Copyright © 2016 by Tennessee Department of Education. All rights reserved. No part of this publication may be copied, reproduced, or distributed in any form or by any means, or stored in a database or retrieval system, without the prior express written consent of the Tennessee Department of Education and Questar Assessment Inc.

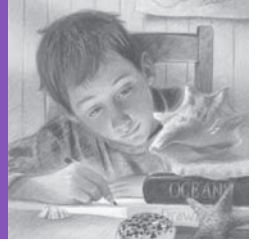

- 1** A food chain is shown below.

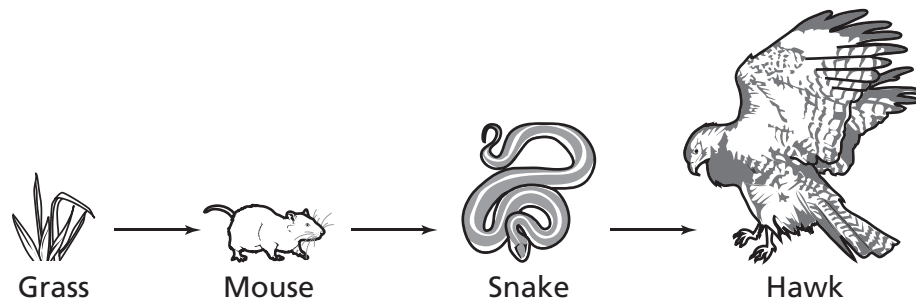

Which organism in the food chain is a producer?

- A** Grass
 - B** Mouse
 - C** Snake
 - D** Hawk
- 2** Wind is considered a renewable resource because the energy that drives the wind originally comes from
- F** the sun.
 - G** rain.
 - H** the ocean.
 - J** oxygen.

Go On ►

3 The length of time it takes Earth to rotate once on its axis is called a

- A** season.
- B** month.
- C** year.
- D** day.

4 Which hot and dry biome is home to large herds of herbivores that feed on the many kinds of grasses?

- F** tundra
- G** desert
- H** rain forest
- J** savannah

5 The diagram shows the sun and Earth.

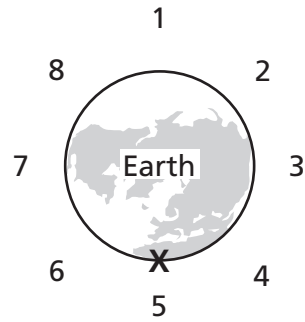
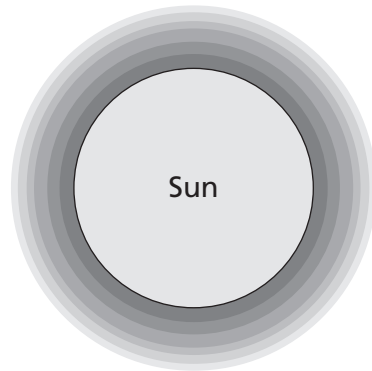

What will cause a high tide to occur at location X?

- A** The moon is at location 2.
- B** The moon is at location 4.
- C** The moon is at location 5.
- D** The moon is at location 7.

6 Which set of objects best conducts electricity?

- F** an iron washer and a metal fork
- G** a door key and a rubber ball
- H** a copper pipe and a wooden spoon
- J** a rubber mallet and a glass measuring cup

Go On ►

7 The diagram shows Earth at four different locations around the sun.

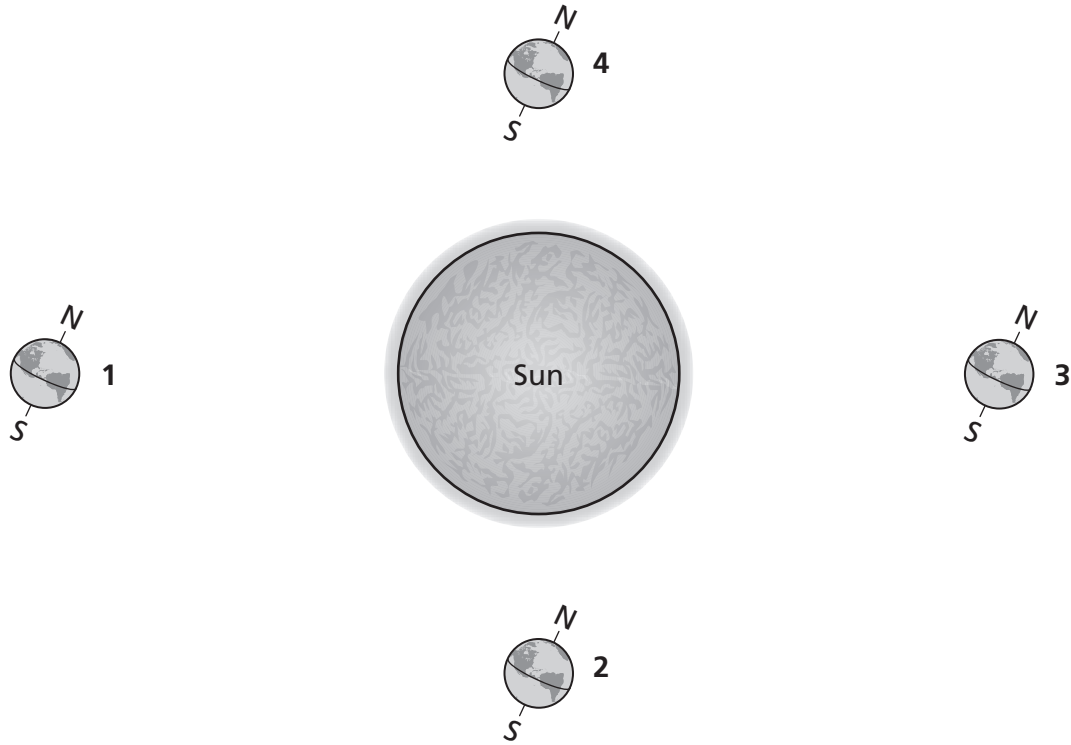

At which location is it summer in Earth's Northern Hemisphere?

- A** 1
- B** 2
- C** 3
- D** 4

8 In a biotic response experiment, two plants with the same mass are placed in identical pots. Both plants are given the same amount of water, soil, and sunlight. After one week, the test plant is given one tablespoon of liquid fertilizer. Two weeks later, the data shows the test plant has the greater mass. What is the independent variable in this biotic response experiment?

- F** amount of sunlight
- G** soil temperature
- H** liquid fertilizer
- J** size of the pot

9 Which is a biotic factor of an alpine forest?

- A** elk
- B** rainfall
- C** soil
- D** mountains

Go On ►

10 A solar eclipse is most likely to occur when Earth, the moon, and the sun are in which location?

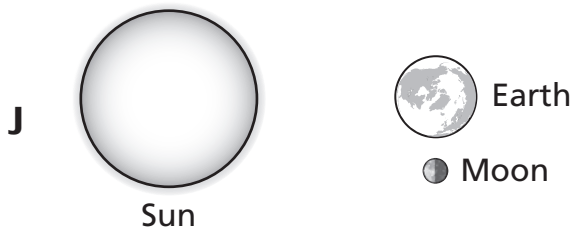
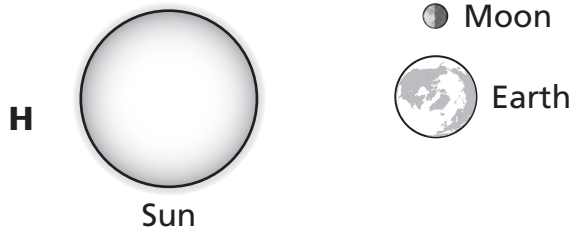
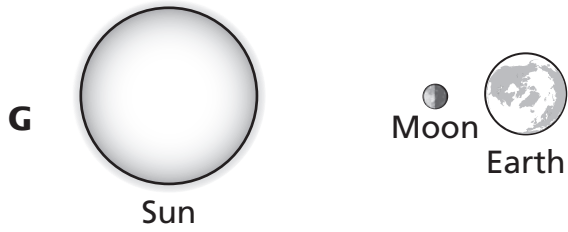
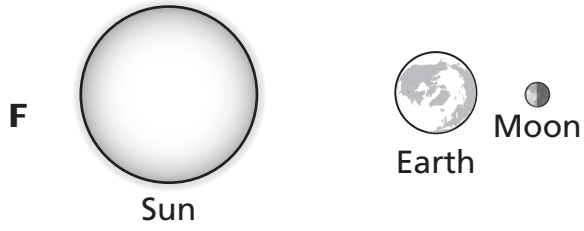

11 Early satellites were used to monitor weather. In which other area have satellites most benefitted humans?

- A** medicine
- B** navigation
- C** fossil exploration
- D** recycled materials

12 The diagram below shows a simple electrical circuit.

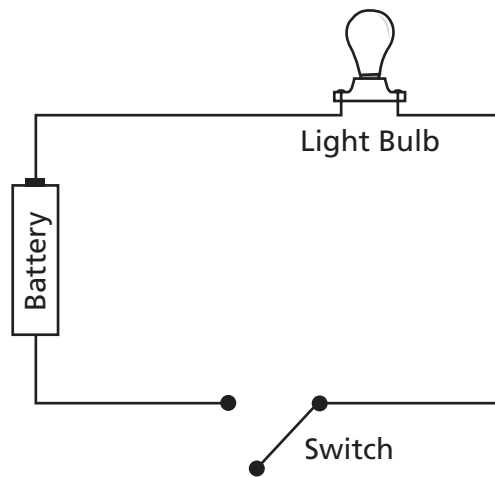

What energy conversions occur when the switch is closed?

- F** chemical energy \rightarrow electrical energy \rightarrow light energy
- G** light energy \rightarrow electrical energy \rightarrow thermal energy
- H** thermal energy \rightarrow electrical energy \rightarrow light energy
- J** light energy \rightarrow chemical energy \rightarrow electrical energy

Go On ►

13 Which occurs when the moon, the sun, and Earth are in a straight line?

- A** first quarter moon
- B** third quarter moon
- C** neap tide
- D** spring tide

14 How is soil fertility in a deciduous forest dependent on the trees?

- F** Fallen leaves decay and make the soil rich with organic matter.
- G** The trees shade the ground so small amounts of light get through to the soil.
- H** Tree roots keep rocks from breaking and adding minerals to the soil.
- J** Large rocks help break down smaller rocks and pebbles in forming soil.

15

The Gulf Stream is a warm water current that begins in the Gulf of Mexico. A diagram of the Gulf Stream is shown below.

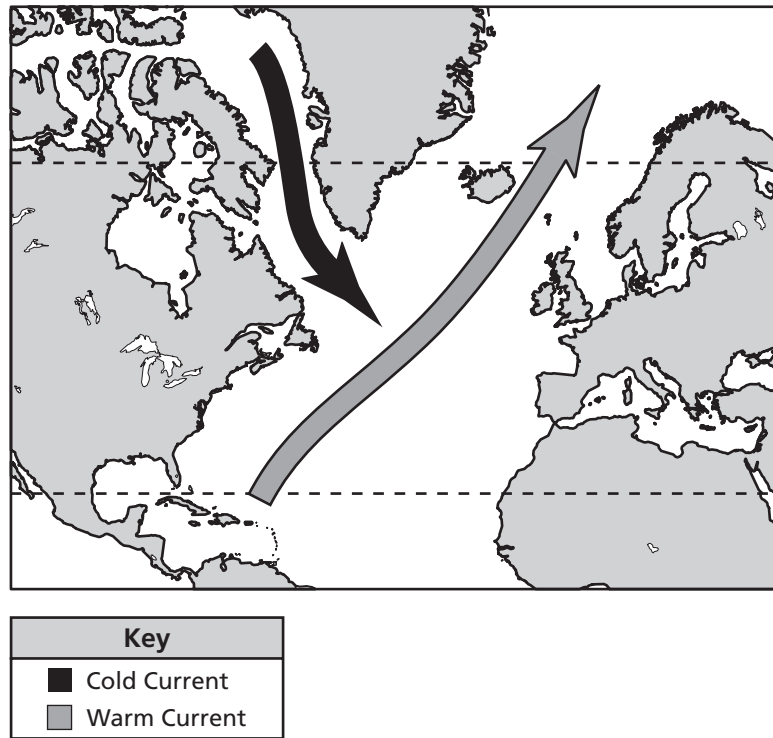

Which best describes the movement of the Gulf Stream?

- A Cold currents carry cold water from the polar zones toward the equator.
- B Warm currents carry warm water from the tropics toward the poles.
- C Warm currents carry cold water from the tropics toward the poles.
- D Cold currents carry warm water from the polar zones toward the equator.

Go On ►

16 The following is a process that takes place in the atmosphere.

solar energy → warm air rises → air cools in upper atmosphere and sinks → air currents

This process can best be identified as

- F wind formation.
- G cloud formation.
- H precipitation runoff.
- J static electricity.

17 Which simple circuit most likely produces heat and light energy?

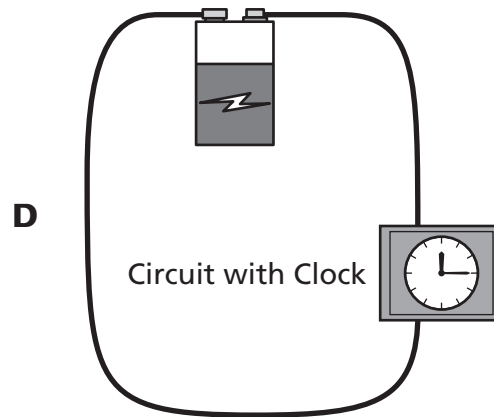
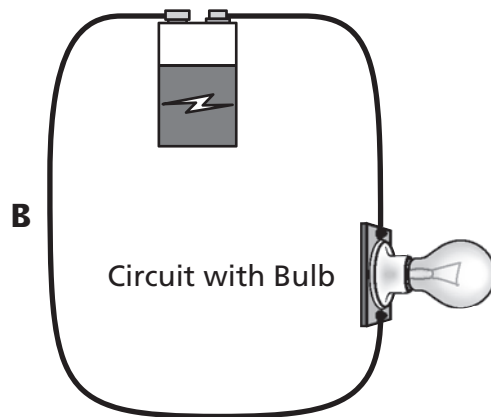
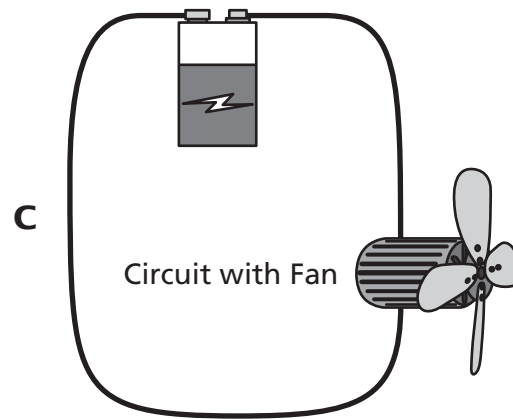
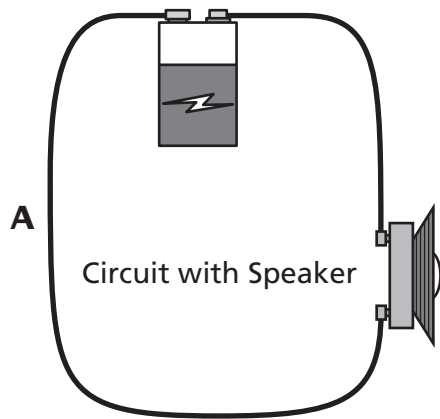

18 The diagram shows a waning crescent moon.

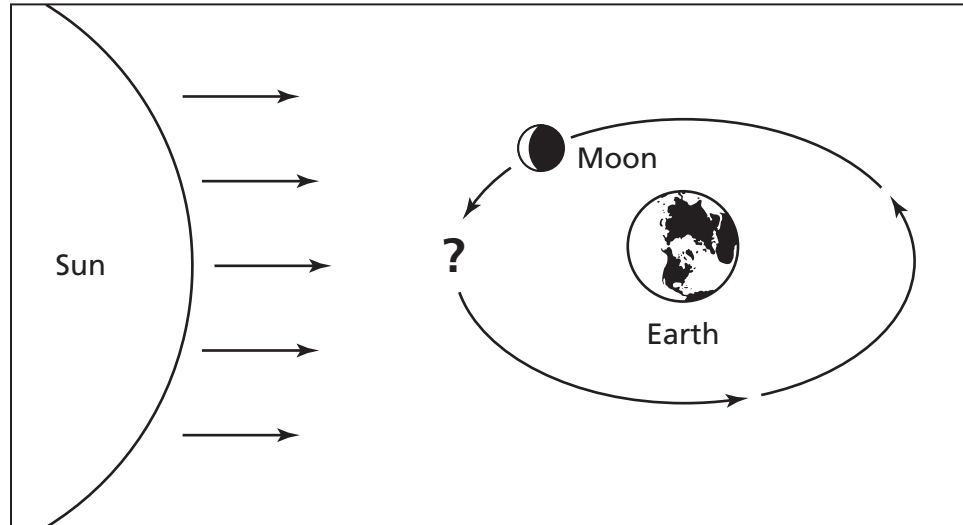

Which moon phase will happen next?

- F** new moon
- G** waning gibbous
- H** full moon
- J** last quarter

Go On ►

- 19** The illustration below shows the locations of a rock as it rolls down a slope.

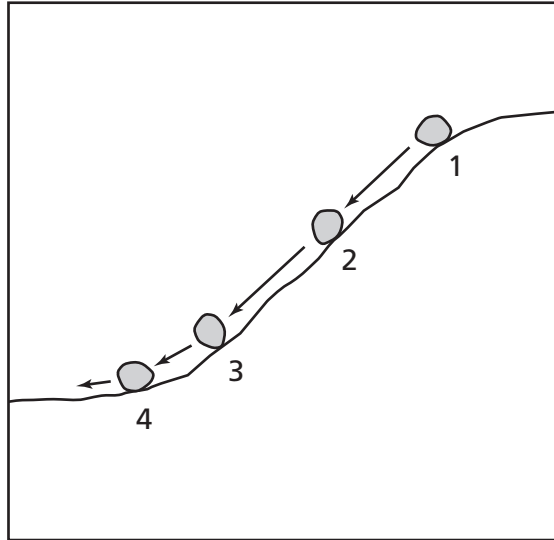

Which location best shows the rock with the greatest kinetic energy and the least potential energy?

- A** 1
- B** 2
- C** 3
- D** 4

- 20** Three healthy plants are placed in a dark cabinet. Another three are placed in a window. All the plants are given the same amount of water. After one month, only the plants in the window are living. These results support which conclusion?

- F** Darkness will cause plants to grow.
- G** Carbon dioxide is needed for growth.
- H** Leaves need more time to grow.
- J** Sunlight is needed for growth.

21 An object moves rapidly as it is thrown upward. Its motion slows as it reaches a maximum height, and then it falls back down. What causes the upward motion to become slower?

- A** The kinetic energy is converted to wind energy.
- B** The kinetic energy is converted to gravitational potential energy.
- C** The gravitational potential energy is converted to kinetic energy.
- D** The gravitational potential energy is converted to light energy.

22 Earth is shown between the sun and the moon in the diagram below.



Which type of moon will be viewed from Earth when Earth is between the sun and the moon?

- F** waning gibbous
- G** waxing crescent
- H** new moon
- J** full moon

23 Which of these contains both abiotic and biotic elements in a desert environment?

- A** rocks and sunlight
- B** water and pebbles
- C** scorpions and sand
- D** roadrunners and snakes

Go On ►

24 A rubber band is stretched between a person's fingers and then released. This best demonstrates

- F** products and reactants.
- G** friction and air resistance.
- H** physical and chemical changes.
- J** potential and kinetic energy.

25 On a summer evening, a barometer reading shows a gradual increase in air pressure. The humidity is 80%. The thermometer reading is slightly increasing. Based on these data, what type of weather should be expected for the next day?

- A** clear and sunny
- B** cool and rainy
- C** rainy and windy
- D** cloudy and cold

26 Water and ketchup are each poured onto a tray from two separate bottles. The charts below represent the amount of time it takes each liquid to flow from the top to the bottom of the tray.

Water Data		Ketchup Data	
Trial #	Time (sec.)	Trial #	Time (sec.)
1	2	1	35
2	3	2	35
3	2	3	40

What conclusion is best supported by the data?

- F** Thicker liquids take longer to travel to the bottom of a tray.
- G** Thicker liquids take less time to travel to the bottom of a tray.
- H** Liquid with sugar crystals travels to the bottom of a tray faster.
- J** Liquid with a darker color travels to the bottom of a tray faster.

- 27** A teacher uses a flashlight, an apple, and a walnut to show a lunar eclipse.

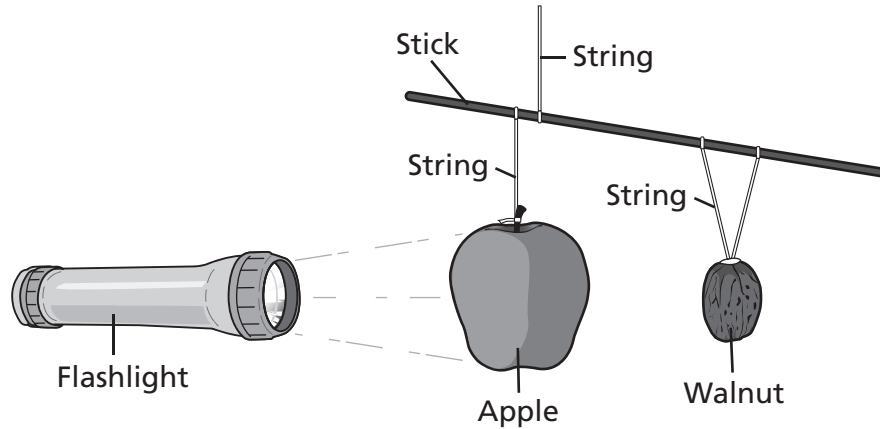

This lab setup best demonstrates that a lunar eclipse occurs during a

- A** new moon.
- B** full moon.
- C** first quarter moon.
- D** crescent moon.

- 28** A meteorologist used radar to analyze the wind during a storm in the central plains of the United States. The winds were measured at 145 miles per hour and were moving in a circular pattern. According to the data, which event was the meteorologist most likely observing?

- F** lightning storm
- G** tornado
- H** rainbow
- J** cloud formation

Go On ►

29 What happens to some of the energy in a green plant when it is consumed by a deer?

- A** It is destroyed.
- B** It doubles in size.
- C** It helps maintain body heat.
- D** It is converted into a pure element.

30 Which type of energy is converted when fireworks release heat, light, and sound?

- F** kinetic energy
- G** elastic potential energy
- H** chemical potential energy
- J** electromagnetic energy

31 A student sees the moon and says, “The moon looks larger than the stars.” Which best explains why the student makes this observation?

- A** The moon is reflecting light from the sun.
- B** The moon is closer to Earth than the stars.
- C** The moon is much larger than the stars.
- D** The moon is much larger than Earth.

32

A group of students researched and collected data for a report on the weather in Nashville, Tennessee, for one year.

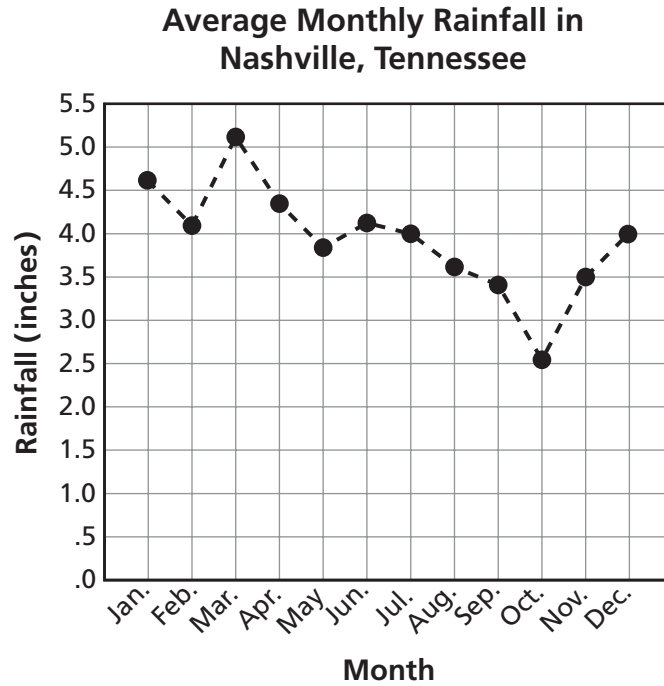

Based on the data, the students concluded that all cities in Tennessee will receive approximately 3.6 inches of rainfall next August. Which best explains why the students' conclusion is incorrect?

- F** The data collected did not include yearly rainfall amounts.
- G** The data collected did not include daily rainfall amounts.
- H** Rainfall averages were collected only from one city.
- J** Rainfall averages were not compared to a previous year.

Go On ►

33 Which type of energy is being converted into kinetic energy as a marble falls from a shelf?

- A** electrical potential energy
- B** gravitational potential energy
- C** elastic potential energy
- D** chemical potential energy

34 A battery is designed to provide improved power supply in areas with extremely low temperatures. Which test best determines if a prototype meets this goal?

- F** Compare the power of the prototype to the power of other standard batteries under normal conditions.
- G** Compare the lifetime of the prototype to that of a standard battery in a wide range of climate conditions.
- H** Compare the power storage of the prototype to that of a standard battery at cold temperatures.
- J** Compare the cost of materials for the prototype to the cost of materials for a standard battery.

Students counted the number of organisms located in a one-meter square plot in a grassland prairie. Their data are shown below.

Population Data

Organism	Number of Organisms
Ants	10
Beetles	2
Indian Grass	3
Goldenrod	4
Bluestem	8

Which graph best represents the data?

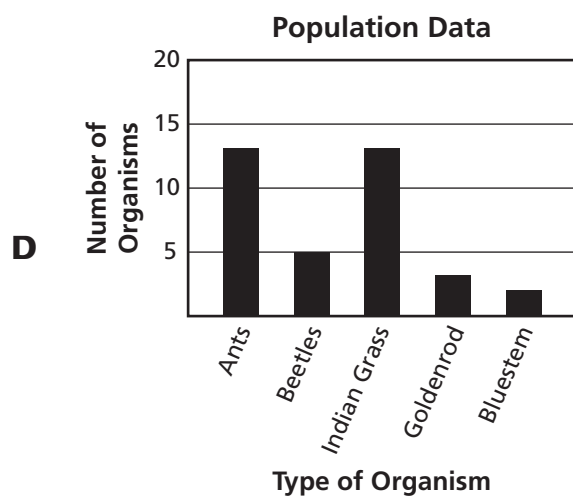
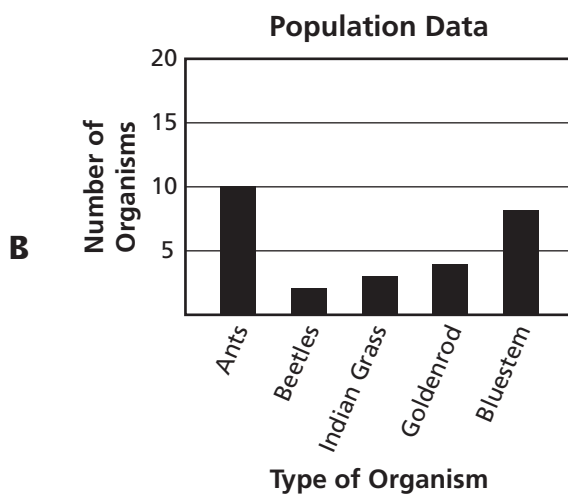
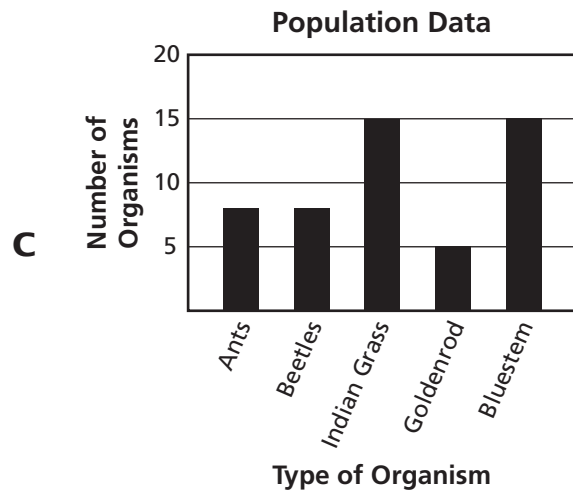
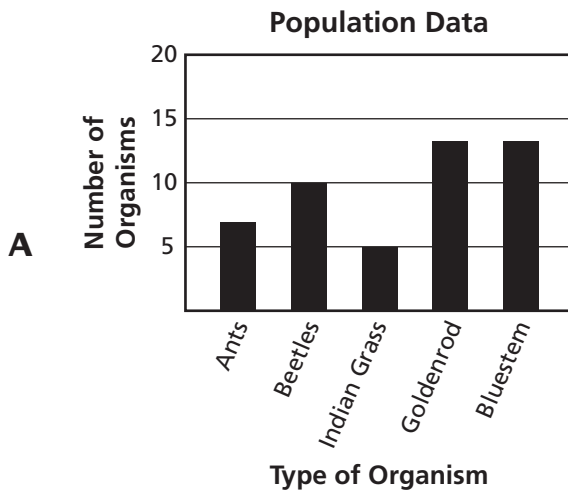

Part 2

36 What energy conversion occurs when a person rubs his or her hands together rapidly?

- F** electrical energy to thermal energy
- G** electrical energy to chemical energy
- H** thermal energy to kinetic energy
- J** kinetic energy to thermal energy

37 A bottle company discovered that caps were being applied with too much force. This caused many bottles to break. Engineers adjusted the capping device so it applies less force to the caps.

Which steps should the engineers take before the adjustment is considered successful?

- A** adjust the capping device to increase the force applied by the bottle caps
- B** replace the bottle caps with different caps that cover a larger bottle opening
- C** compare the company's capping process to other companies' processes
- D** inspect bottles that have passed through the capping device after the adjustment

38 The table below shows how hurricanes are classified based on the Saffir-Simpson scale.

Hurricane Classifications

Classification	Wind Speed (mph)	Level of Damage
Tropical storm	39–73	Minor
Category 1 hurricane	74–95	Minor damage, coastal flooding
Category 2 hurricane	96–110	Some structural damage, coastal flooding
Category 3 hurricane	111–130	Moderate damage, inland flooding
Category 4 hurricane	131–155	Major damage, flooding well inland
Category 5 hurricane	156 and higher	Severe damage, substantial inland flooding

One hour after a hurricane hit land, its wind speed had fallen to 98 miles per hour. What was the classification of the hurricane at that time?

- F** Category 1 hurricane
- G** Category 2 hurricane
- H** Category 3 hurricane
- J** Category 4 hurricane

39 What type of energy transfer is taking place as the coils in a toaster heat?

- A** chemical to thermal
- B** nuclear to electrical
- C** thermal to mechanical
- D** electrical to radiant

Go On ►

- 40** The data table shows land and water temperatures along a beach during a one-day period.

Coastal Temperatures Data Table

Land Temperature (°C)	Water Temperature (°C)
24	22
28	22
33	23
32	25

In what way can the data be used to make a prediction?

- F** Inland temperatures will help cause tidal surges.
- G** Water temperatures will help determine coastal temperatures.
- H** Coastal temperatures will help determine sea levels.
- J** Water temperatures will help cause inland soil erosion.

- 41** A company designed an electromagnetic tool that removes dents from metal plates. The dented metal is placed between two magnets. A current is then supplied to the electromagnets. The attraction between the two magnets forces the dented metal plate back into place. How can engineers test to see if their design is successful?

- A** compare the cost of operating the tool to other dent removal tools
- B** compare the shape of the treated metal with the original shape of the metal
- C** compare the type of metal plates treated by the company to those of other companies
- D** compare the energy requirements of two similar dent removal tools

42

Which diagram best shows the position of Earth, the moon and the sun when there is a new moon?

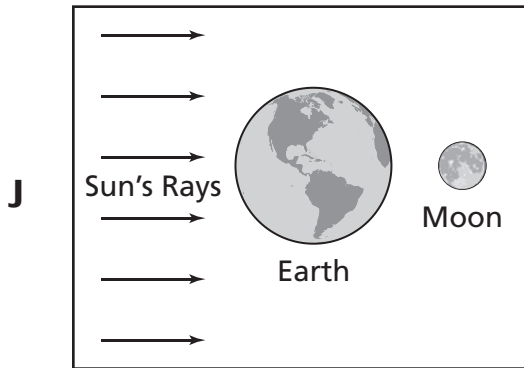
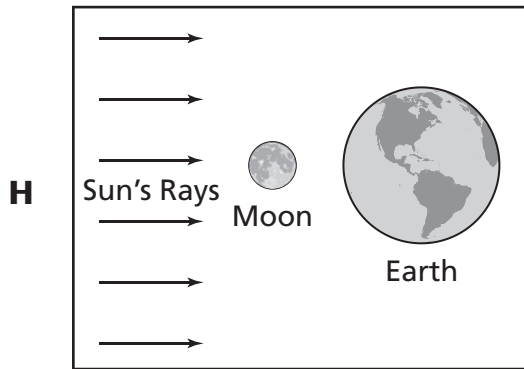
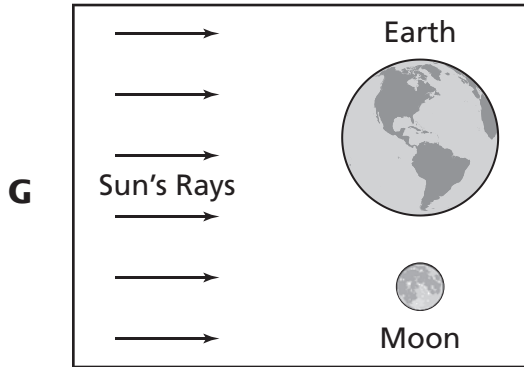
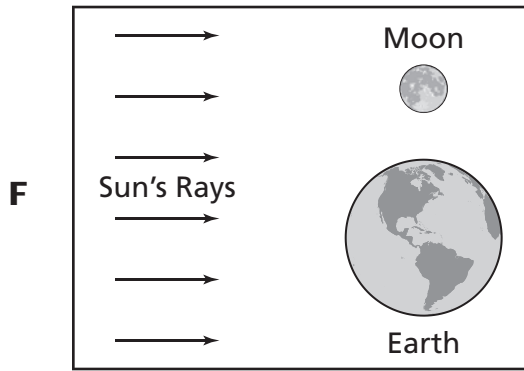

Go On ►

43 A diagram of a roller coaster moving to the top of a hill is shown below.

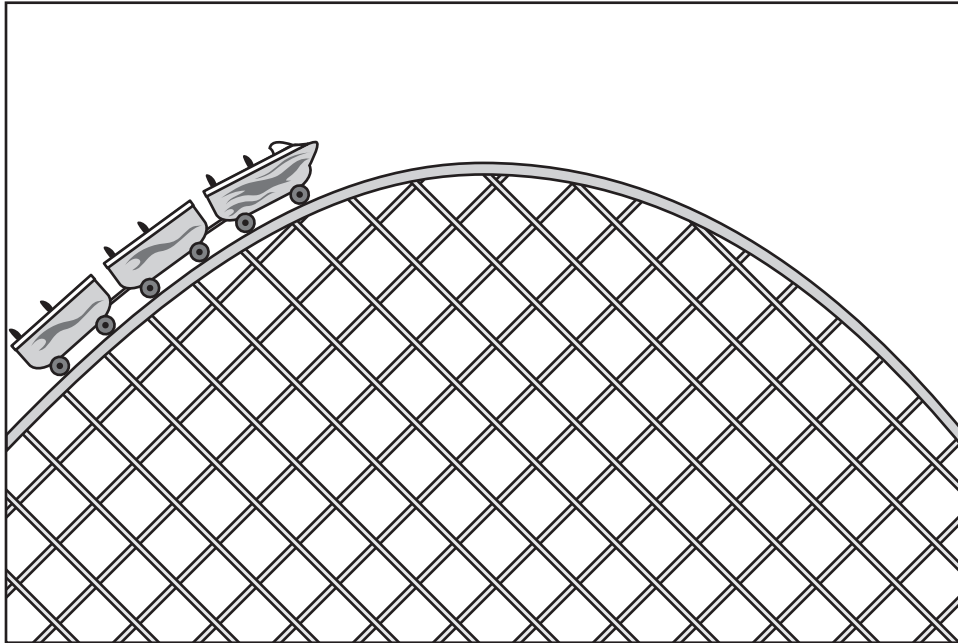

Which type of energy will be greatest at the top of the hill?

- A** chemical potential energy
- B** nuclear potential energy
- C** elastic potential energy
- D** gravitational potential energy

- 44** The table lists some characteristics of objects in our solar system.

Objects in Our Solar System

Object	Location	Diameter
Asteroid	Orbits the sun	Up to 1,000 km
Moon	Orbits a planet	Up to 5,268 km
Halley's Comet	Orbits the sun	8 km
Planet in solar system	Orbits the sun	4,880–142,800 km

Scientists observe an object with a diameter of 950 km in an orbit around the sun. Scientists will most likely identify it as which type of object?

- F** Asteroid
- G** Moon
- H** Comet
- J** Planet

Go On ►

- 45** When a button is pushed, a circuit is completed and a buzzer is activated. The buzzer transferred electrical energy into
- A** sound energy.
 - B** chemical energy.
 - C** light energy.
 - D** nuclear energy.

- 46** Which is the best example of an assistive bioengineered product?
- F** a rosebush that is bred to have roses of a particular color
 - G** a computer program that helps a paralyzed person control a wheelchair
 - H** a pesticide produced from the compounds of a plant
 - J** a bacterium that generates oil byproducts in the presence of sunlight

47 A grassland food web is shown below.

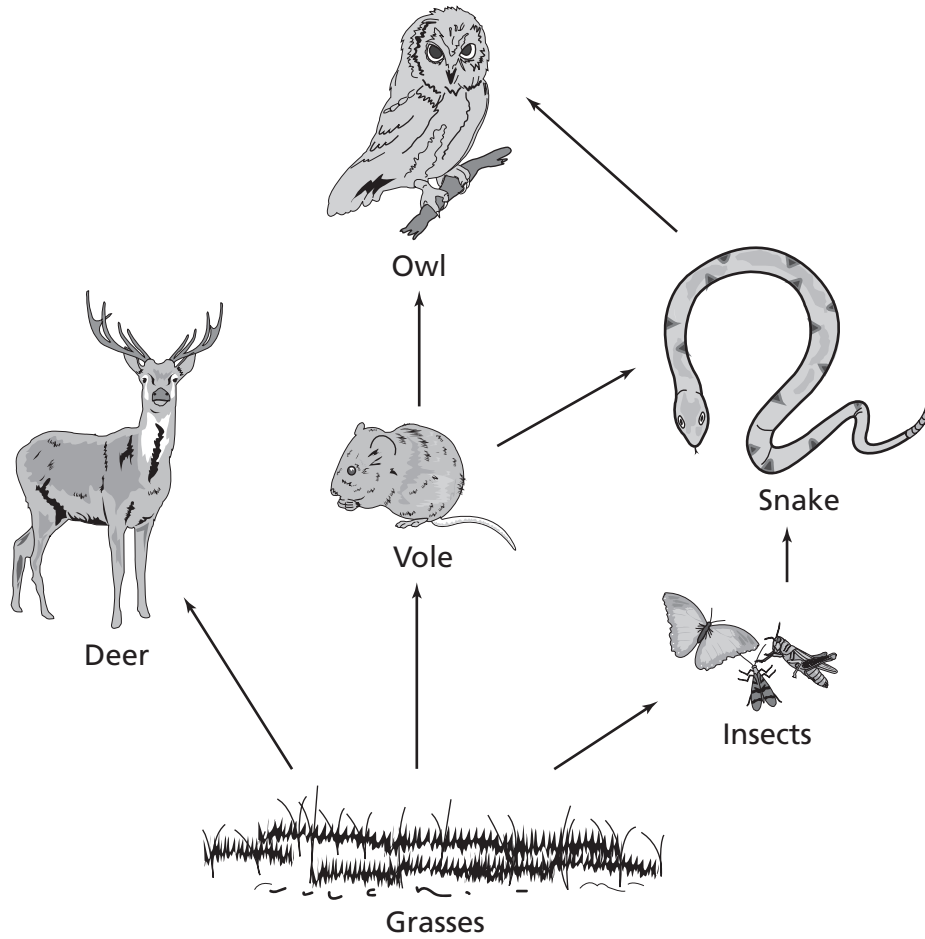

The owl most directly obtains energy from which organism?

- A** Vole
- B** Insects
- C** Deer
- D** Grasses

Go On ►

48 Which diagram best represents one day on Earth?

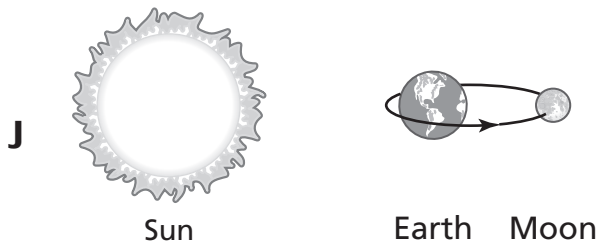
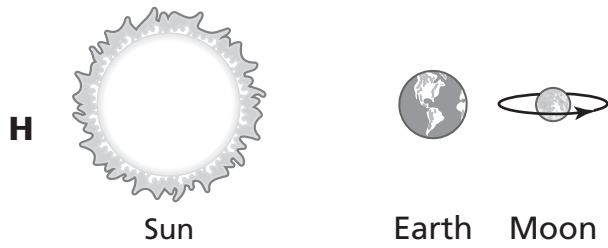
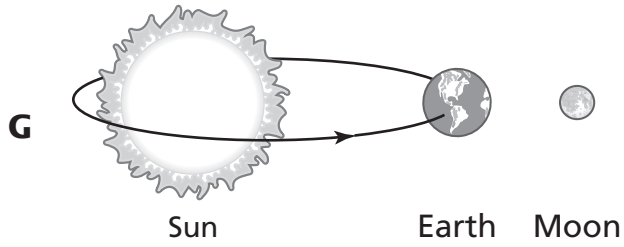
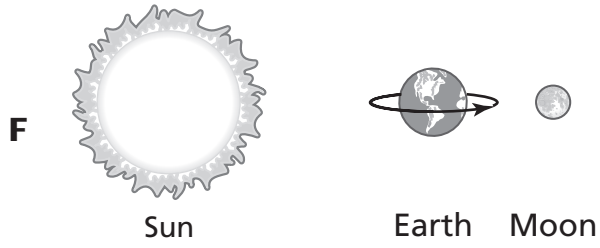

49 Which is the best example of chemical potential energy?

- A** a book resting on a shelf
- B** a stretched rubber band
- C** a fuel tank containing gasoline
- D** a pencil falling off a table

50 Cold ocean currents are most likely to be located at deeper ocean depths than warm water currents because

- F** winds push the cold water down.
- G** ocean tides force cold water downward.
- H** cold water is more dense and sinks.
- J** cold water has less salt to help it freeze and sink.

Go On ►

51 A prairie food web is shown below.

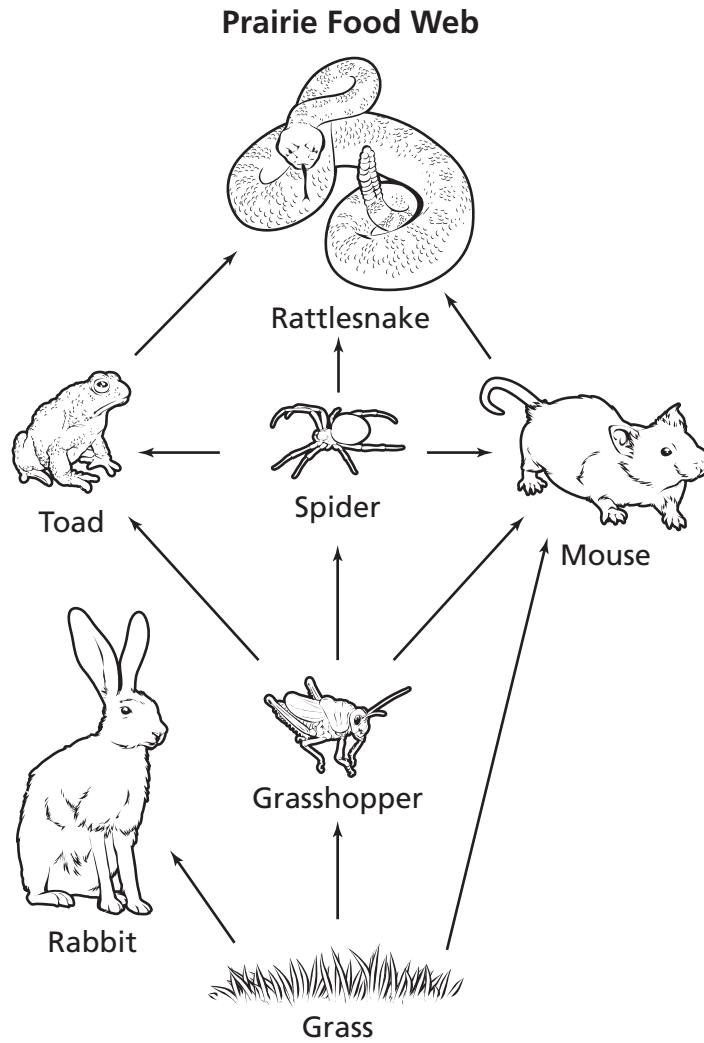

Which group of organisms is made up of only consumers?

- A** Spider, Grass, Mouse
- B** Toad, Grass, Rabbit
- C** Grasshopper, Mouse, Grass
- D** Rattlesnake, Grasshopper, Spider

52 What can happen when the moon passes between Earth and the sun?

- F** The sun lights both sides of the moon.
- G** The moon blocks the light of the sun.
- H** The sun blocks the view of the moon.
- J** The moon stops the sun from producing light.

Go On ►

53 A diagram of the sun, Earth, and the moon is shown below.

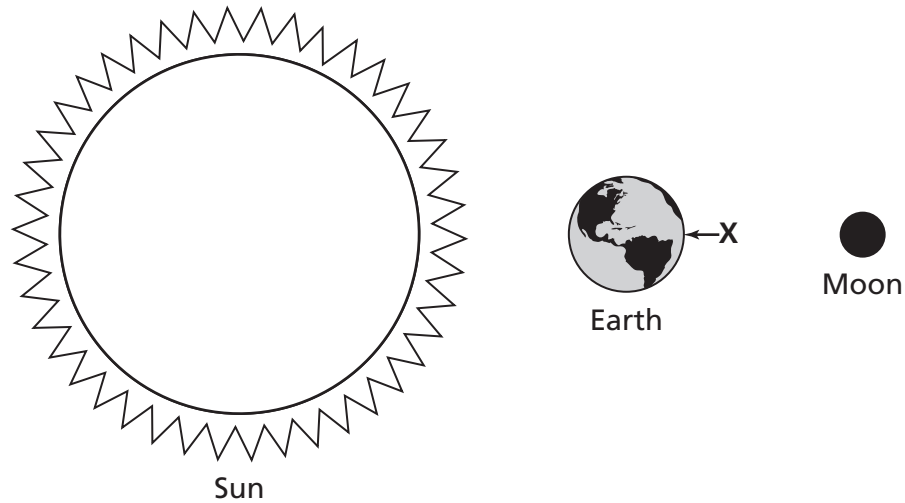

When the sun, Earth, and the moon are aligned in the positions shown in the diagram, what type of ocean tide occurs at location X?

- A** red tides near the coast
- B** rip tides near the coast
- C** highest high tides
- D** lowest high tides

54 Which most likely causes the movement of warm surface ocean currents?

- F** Sunlight heats air forming strong winds that push currents.
- G** Low and high tides create energy for current movement.
- H** Shifting ocean plates force water toward the poles.
- J** Warm waters help in the melting of icebergs and glaciers.

55

Each diagram shows a circuit. The number one represents a buzzer and the number two represents a clock. Which diagram most likely shows a circuit producing sound?

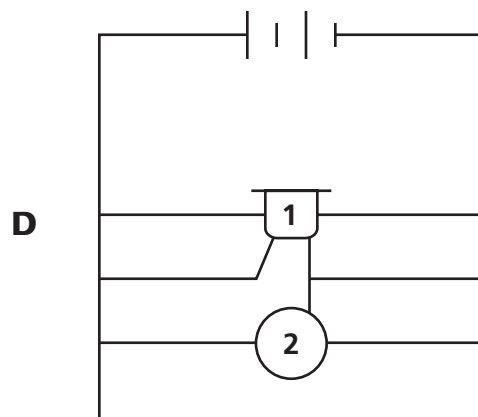
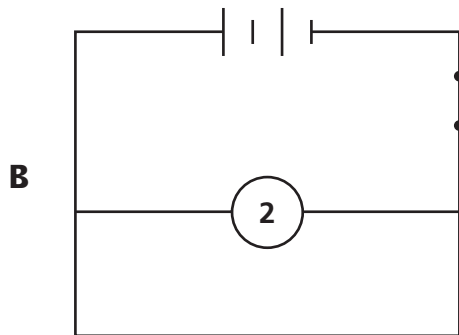
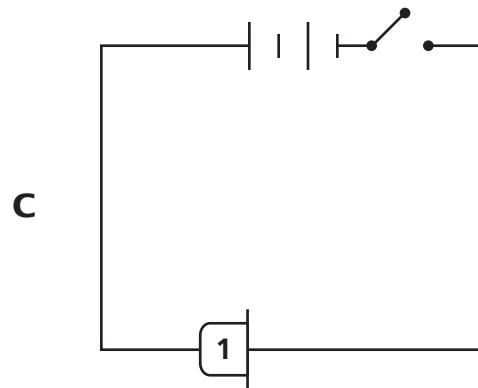
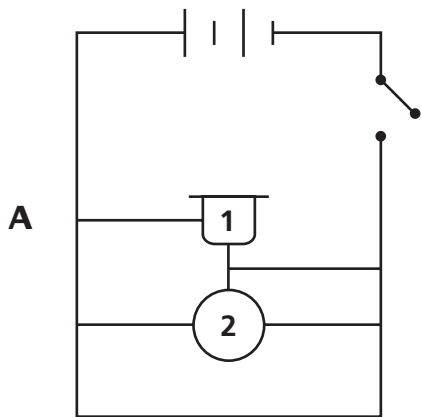

Go On ►

56 The drawing below shows a sea breeze.

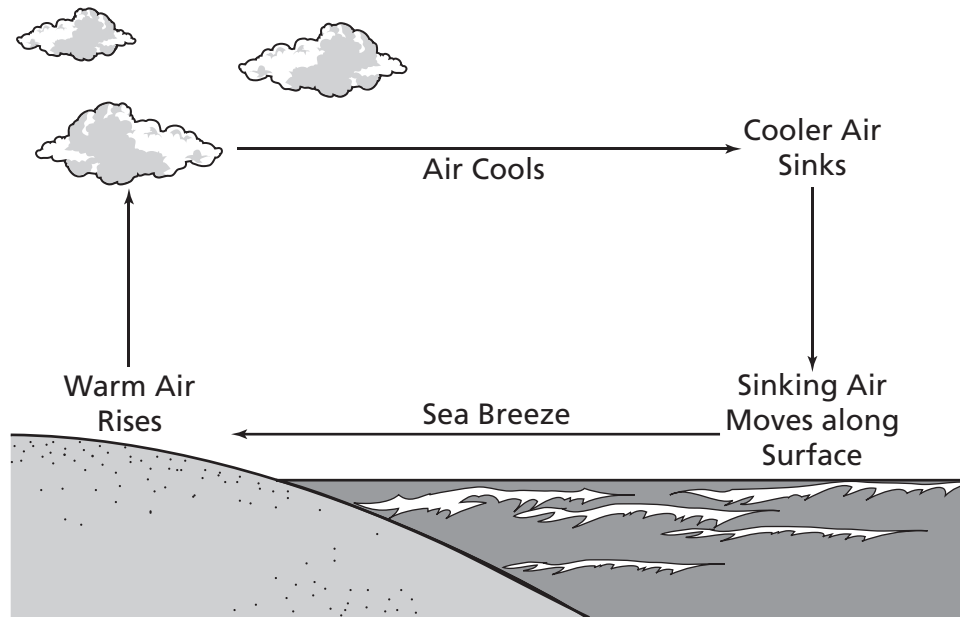

When is this type of wind pattern most likely to occur?

- F** during the day when the land heats faster than the surface of the sea
- G** during the night when the surface of the sea cools faster than the land
- H** during the day when the sea is as warm as the land
- J** during the night when the air above land is warmer than the air above the sea

57 Inside a power plant, coal is burned to produce hot gases. What type of energy conversion takes place as hot gases cause turbines to move?

- A** thermal energy to chemical energy
- B** thermal energy to kinetic energy
- C** electrical energy to kinetic energy
- D** kinetic energy to thermal energy

58 The Arctic tundra provides a habitat for caribou and arctic hare. Which best describes the climate in which these animals live?

- F** cold and humid
- G** warm and dry
- H** cold and dry
- J** warm and humid

59 Venus appears very bright in the night sky because it

- A** has a gravitational field.
- B** is the largest planet.
- C** is the closest planet to Earth.
- D** has a high surface temperature.

60 When turning on a flashlight, a chemical reaction in the battery produces electricity that lights a bulb.

According to the Law of Conservation of Energy, the energy exchanged between the battery and the flashlight

- F** is created.
- G** loses matter.
- H** is destroyed.
- J** changes forms.

Go On ►

61 The barometer reading on a local weather forecast was 29.80 mm Hg and falling. What type of weather conditions are most likely about to occur?

- A clear and cool
- B clear and warm
- C fair skies
- D cloudy skies

62 The soil in a deciduous forest typically contains many nutrients and supports the growth of various plants. Which statement explains why the soil is so nutrient rich?

- F The daily rainfall adds minerals to the soil.
- G The temperature of the soil is perfect for plants to grow.
- H The amount of sunlight the soil gets is perfect for plants.
- J The soil is high in organic matter from decomposers.

63 Ocean currents bring deep, nutrient-rich water to the surface. What causes these currents to move upward?

- A** Warm rainwater mixes with surface water, pushing deep water upward.
- B** Cold surface water from the poles sinks, pushing deep water upward.
- C** Wind currents cause surface water to sink, pushing deep water upward.
- D** Surface runoff from rivers causes warm water to sink, pushing deep water upward.

64 A ball is at rest until a paddle exerts force as shown below.



What kind of energy is shown by the ball as it is moving away from the paddle?

- F** potential energy
- G** kinetic energy
- H** chemical energy
- J** nuclear energy

Go On ►

65 Which organisms are most important for adding nutrients to the soil?

- A** consumers
- B** scavengers
- C** producers
- D** decomposers

66 What causes a lunar eclipse to occur?

- F** The moon's shadow falls on Earth.
- G** Earth's shadow falls on the moon.
- H** The moon's shadow falls on the sun.
- J** The sun's shadow falls on Earth.

67 Which tool is most useful to observe the moons of Jupiter to help record their motion?

- A** microscope
- B** telescope
- C** balance
- D** binoculars

68 Approximately how long does it take the moon to complete one cycle of phases?

- F** a month
- G** a day
- H** a year
- J** a week

69 Which activity within our solar system takes approximately one year to complete?

- A** Halley's comet revolving around the sun once
- B** a distant star revolving around Earth once
- C** Earth revolving around the sun once
- D** the moon revolving around Earth once

This page is intentionally left blank.

Name: _____

1. (A) (B) (C) (D)

2. (F) (G) (H) (J)

3. (A) (B) (C) (D)

4. (F) (G) (H) (J)

5. (A) (B) (C) (D)

6. (F) (G) (H) (J)

7. (A) (B) (C) (D)

8. (F) (G) (H) (J)

9. (A) (B) (C) (D)

10. (F) (G) (H) (J)

11. (A) (B) (C) (D)

12. (F) (G) (H) (J)

13. (A) (B) (C) (D)

14. (F) (G) (H) (J)

15. (A) (B) (C) (D)

16. (F) (G) (H) (J)

17. (A) (B) (C) (D)

18. (F) (G) (H) (J)

19. (A) (B) (C) (D)

20. (F) (G) (H) (J)

21. (A) (B) (C) (D)

22. (F) (G) (H) (J)

23. (A) (B) (C) (D)

24. (F) (G) (H) (J)

25. (A) (B) (C) (D)

26. (F) (G) (H) (J)

- 27. (A) (B) (C) (D)
- 28. (F) (G) (H) (J)
- 29. (A) (B) (C) (D)
- 30. (F) (G) (H) (J)
- 31. (A) (B) (C) (D)
- 32. (F) (G) (H) (J)
- 33. (A) (B) (C) (D)
- 34. (F) (G) (H) (J)
- 35. (A) (B) (C) (D)
- 36. (F) (G) (H) (J)
- 37. (A) (B) (C) (D)
- 38. (F) (G) (H) (J)
- 39. (A) (B) (C) (D)
- 40. (F) (G) (H) (J)
- 41. (A) (B) (C) (D)
- 42. (F) (G) (H) (J)
- 43. (A) (B) (C) (D)
- 44. (F) (G) (H) (J)
- 45. (A) (B) (C) (D)
- 46. (F) (G) (H) (J)
- 47. (A) (B) (C) (D)
- 48. (F) (G) (H) (J)
- 49. (A) (B) (C) (D)
- 50. (F) (G) (H) (J)
- 51. (A) (B) (C) (D)
- 52. (F) (G) (H) (J)
- 53. (A) (B) (C) (D)

-
54. (F) (G) (H) (J)
55. (A) (B) (C) (D)
56. (F) (G) (H) (J)
57. (A) (B) (C) (D)
58. (F) (G) (H) (J)
59. (A) (B) (C) (D)
60. (F) (G) (H) (J)
61. (A) (B) (C) (D)
62. (F) (G) (H) (J)
63. (A) (B) (C) (D)
64. (F) (G) (H) (J)
65. (A) (B) (C) (D)
66. (F) (G) (H) (J)
67. (A) (B) (C) (D)
68. (F) (G) (H) (J)
69. (A) (B) (C) (D)

This page is intentionally left blank.

Science Answer Key

1	A
2	F
3	D
4	J
5	C
6	F
7	A
8	H
9	A
10	G
11	B
12	F
13	D
14	F
15	B
16	F
17	B
18	F

19	C
20	J
21	B
22	J
23	C
24	J
25	A
26	F
27	B
28	G
29	C
30	H
31	B
32	H
33	B
34	H
35	B
36	J

37	D
38	G
39	D
40	G
41	B
42	H
43	D
44	F
45	A
46	G
47	A
48	F
49	C
50	H
51	D
52	G
53	C
54	F

55	D
56	F
57	B
58	H
59	C
60	J
61	D
62	J
63	B
64	G
65	D
66	G
67	B
68	F
69	C